

TOMA AWNING

INSTRUCTION MANUAL

For web site common



Dear customers



Thank you very much for purchasing TOMAAWNING this time.

- Please use correctly this product after you surely read this instruction manual.
- Please carefully store this manual at the place users can take this out any time.

CONTENTS

1. NOTES OF THIS PRODUCT.....	2
Pasting position of important label.....	2
2. PRODUCT SPECIFICATIONS & NAME OF EACH PART	3
3. PREPERATION BEFORE USE	4
4. HOW TO USE	4
5. INSPECTION & OTHERS	5
Working Instruction.....	5
Troubleshooting.....	5
6. EMERGENCY RESPONCE	6
7. AFTER-SALES SERVICE	7
About parts for repairs	7
Information of customer consultation center.....	7

1. NOTES OF THIS PRODUCT

 WARNING	This indicates the content to be assumed the possibility users might die or are seriously injured in case of using wrongly.
 CAUTION	This indicates the content to be assumed possibility users might become disable owing to flammability or occurrence of only property damage.

Pasting position of important label

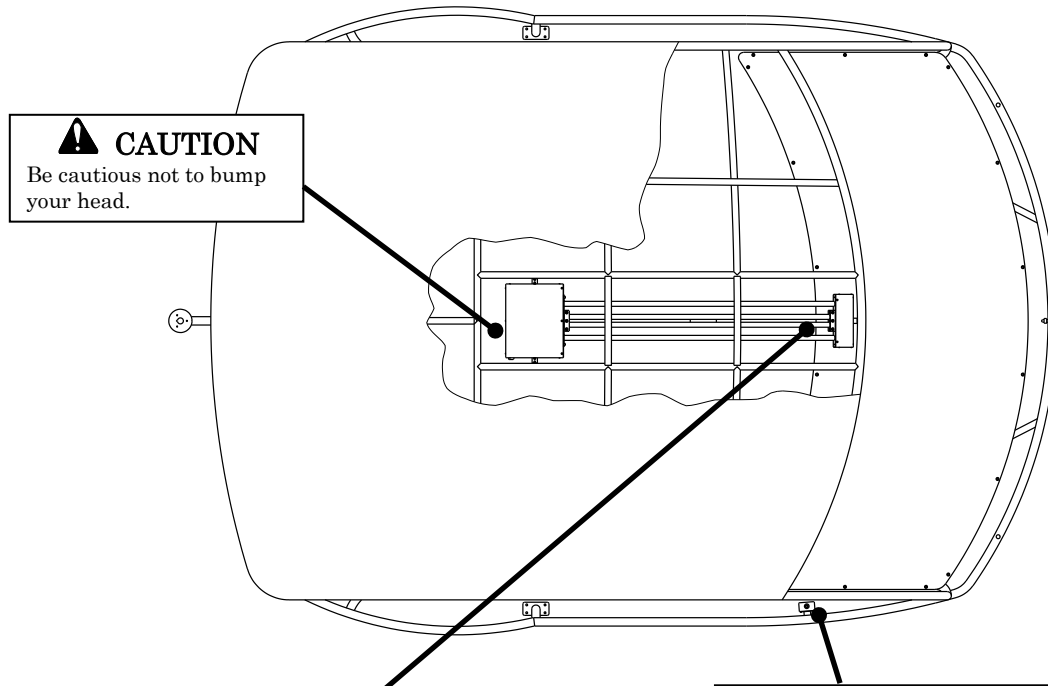

WARNING

There is danger of clash, etc. when keep cruising in low front visibility. Please pull up windshield in case of being in low front visibility. Please lock the windshield pulling it up by your hand with attached tools in case that you couldn't pull it up owing to breakdown of motor, etc.

WARNING

Please operate this after you carefully check the surrounding situation when operating opening/closing switch. Please take your finger off immediately when window stop at upper edge and lower edge in range of motion when operating this.

※We'd like to make a request.

Please read this part to protect you from damage, deterioration, or malfunction of product or property damage.

- We adopt polycarbonate (thickness : 5 mm (0.2 in.)) for windshield. This material is characteristic of getting fine scratch easily although this has very high impact strength. When washing stain, etc., please wash them by fresh water with soft towel, etc.
- In case of oil stain, please wash it with commercially available neutral detergent.
- Please don't use water repellent for car windshield. The surface of windshield (resin) will be invaded and visibility will be impaired.

- Please don't pour water directly by hose, etc. on opening/closing unit. It will be cause of breakdown by entering water.

2. PRODUCT SPECIFICATIONS & NAME OF EACH PART

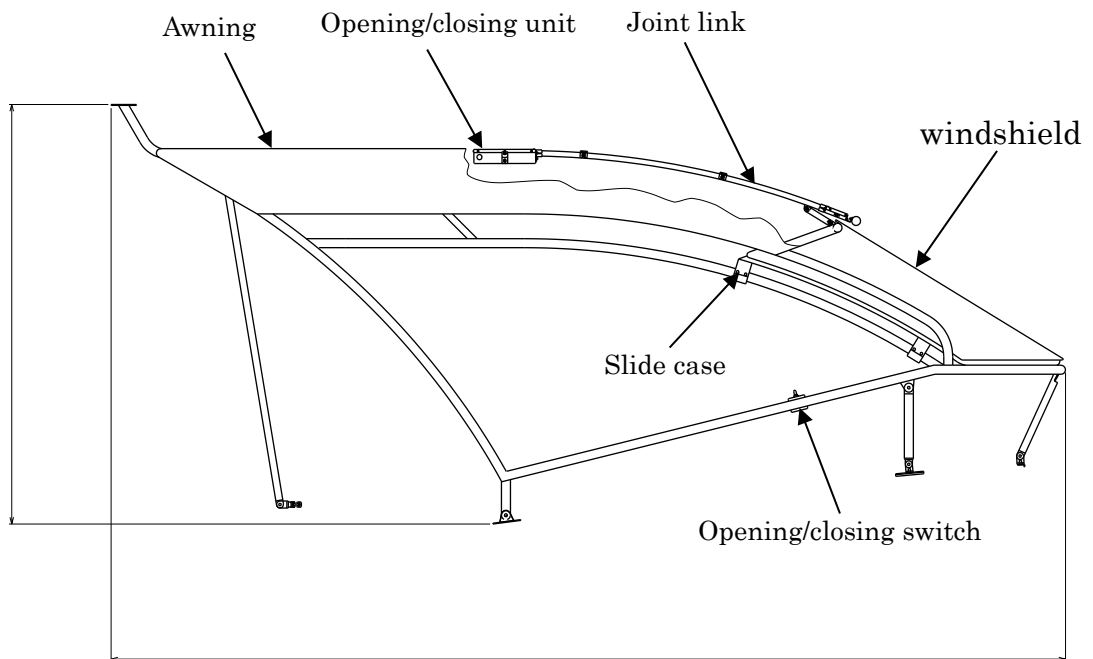
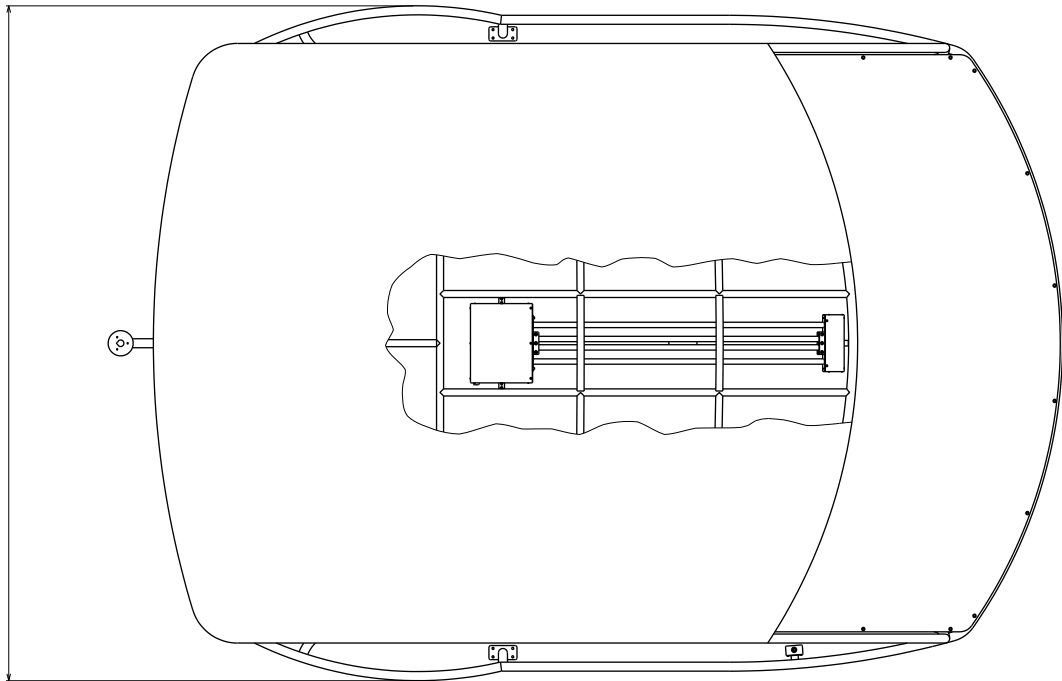

3. PREPERATION BEFORE USE

- 1 · Confirm whether there is stain on windshield to disturb the front vision.
- 2 · Confirm the operation of opening and closing windshield by switch after turning on main switch of yacht.
- 3 · Confirm whether there is abnormal noise , etc. when operating windshield.

4. HOW TO USE

Windshield will be closed when pushing forward the switch and windshield will be opened when pushing backward the switch (picture 1).



Picture 1

NOTE: Operate opening/closing switch after you confirm surrounding situation.

Ex.1. Confirm whether passengers don't grab the rail (Picture 2).

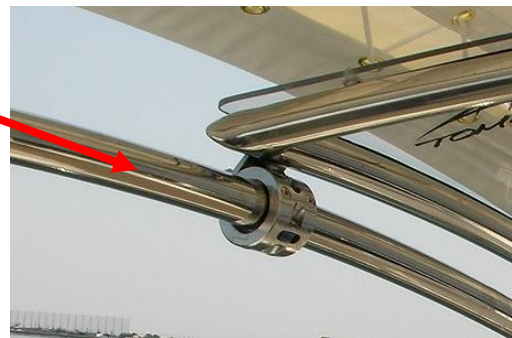

Picture 2



Picture 3

Ex.2. Confirm whether passengers lean forward on yacht (Picture 3).

5. INSPECTION & OTHERS

Working Instruction

- 1 · Scratches by polishing or UV degradation on windshield make visibility from drivers low for a few years.
We recommend you to exchange windshield every 4 years.
- 2 · Please lubricate oil on roller parts (Picture 4) in slide case every 1~2 month(s).
- 3 · We recommend you to store windshield under awning after use to make windshield durable for the long run.

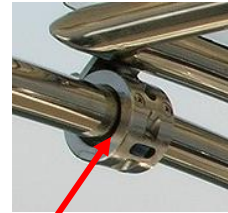

Picture 4

Lubricate oil

Troubleshooting

Please confirm before you request repairing. Those symptoms are not breakdown.

Symptom : Windshield doesn't move when operating opening/closing switch.

Causes & recovery method 1 : The circuit protector will work as safety device to protect opening/closing unit from flowing excess current in some factors (Picture 6).

In that case, please push the rubber cap (Picture 5) by something like a remover bar until you hear click sound. Then the protector will recover (Picture 7).



Rubber cap

Picture 5



Picture 6



Picture 7

Causes & recovery method 2 : The thermal protector will work to protect from the breakdown and other disaster prevention when moving windshield frequently at high temperature in midsummer or when motor produces abnormal heat. In that case, after you leave the protector for a while and it gets cooler naturally, it will recover automatically.

6. EMERGENCY RESPONSE

In case of low front visibility owing to stain on windshield in the situation of that windshield doesn't move because of breakdown, etc., please keep the visible space by pulling it up forcibly following these steps below (Picture 8).

- 1 · Please take off the upper bolt on joint link connected to opening/closing unit and windshield by using attached tools.
- 2 · Please pull up the windshield.
- 3 · Please connect the joint link to bracket installed on the opening/closing unit by using bolt that you took off.

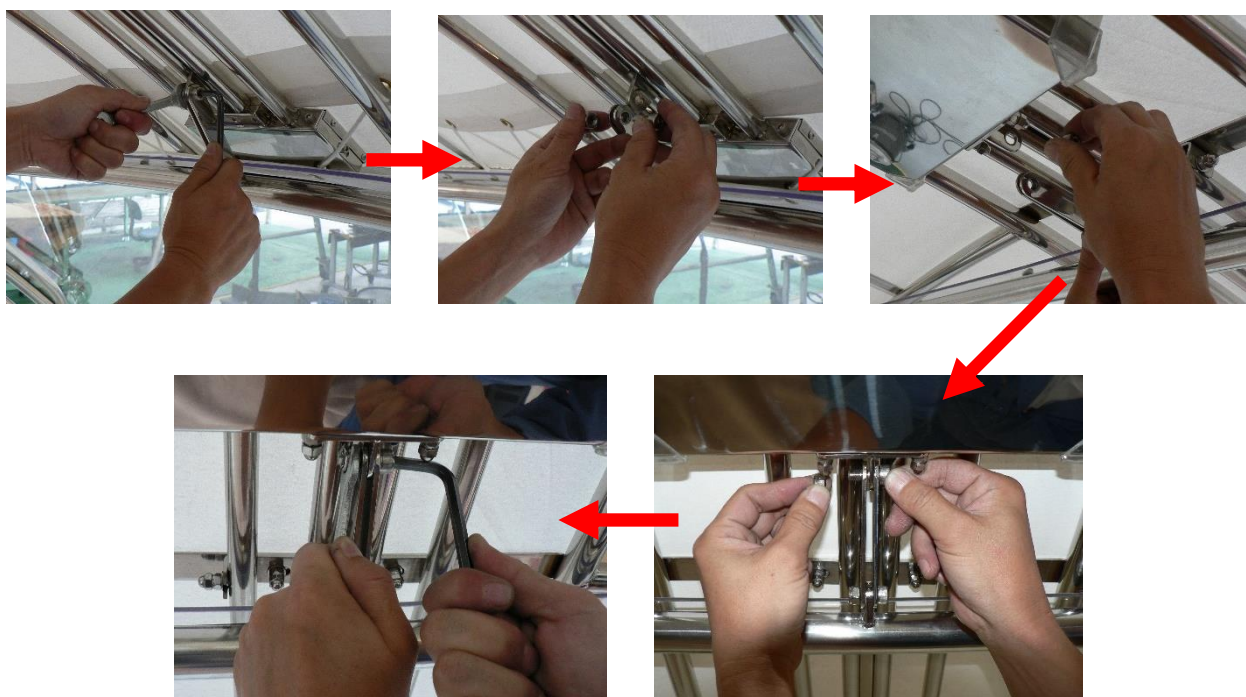

Picture 8

7. AFTER-SALES SERVICE

About parts for repairs

Parts for repairs are necessary parts to maintain the function of the product.

Minimum holding period of these parts for repairs is 5 years after the production is built out.

Information of customer consultation center

Please consult store that you purchase or our company about inquiry or consultation for TOMA AWNING.

Title of consultation	
Yacht that fit TOMA AWNING	Model year
The day of purchase	month date year
Contents of consultation	Be as specific as possible

MARUBISHI MANUFACTURING Co., Ltd.

TEL : +81-568-31-8414

Reception time Mon~Fri (except holiday)

10:00~12:00 13:00~17:00

COPY IS NOT ALLOWED WITHOUT PERMISSION

NAME : TOMA AWNING INSTRUCTION MANUAL

DOCUMENT NUMBER : TOMA-website-01

ISSUE : MARUBISHI MANUFACTURING Co., Ltd.

DATE OF ISSUE : NOVEMBER, 2022